

# SS1 Electrical Enclosure

# IP-SS302015

**STAINLESS STEEL | SINGLE DOOR | IP66**

**300H x 200W x 150D**

**IP Enclosures SS1 Range of grade 316/316L Stainless Steel electrical enclosures are suitable for general industrial applications.**

**Protection:** Complies with IP66 IK10, NEMA 4x (Independent accredited test laboratory)

**Standard:** IEC62208, IEC/EN/AS60529 (IEC/EN/AS61439 Compliant, Optional UL508A)



**Material:**

- Body: 1.5mm Grade 316/316L Stainless Steel
- Door: 1.5mm Grade 316/316L Stainless Steel
- Device Mounting Plate: 1.5mm galvanised steel sheet
- Seal: Polyurethane

**Surface Finish:** 0.4 micron Ra surface brushed finish

**Body:** The robust monoblock body is fabricated using 1.5mm Grade 316/316L Stainless Steel. Flat face sealing surfaces are provided to increase seal life. Pre-fitted blind nutserts are incorporated to accommodate mounts and accessory fasteners to eliminate drilling and retain IP rating. Integral device mounting plate mounts and M6 earth stud is provided.

**Door:** The robust surface mounted door is fabricated using 1.5mm Grade 316/316L Stainless Steel and incorporates concealed removable hinges with captive pins. The door is designed for a 110° opening. Each door contains integral cable management rail studs, M6 earth stud.

**Seal:** A high quality machine-applied continuous foamed in place (FIP) Polyurethane seal provides excellent sealing over a long life.

**Lock:** SS 8mm square drive quarter turn lock with key.

**Device Mounting Plate:** The device mounting plate is fabricated using 1.5mm galvanised steel sheet, pressed to provide additional strength and supplied pre-fitted into enclosure as standard.

**Mass:** 4.8kg

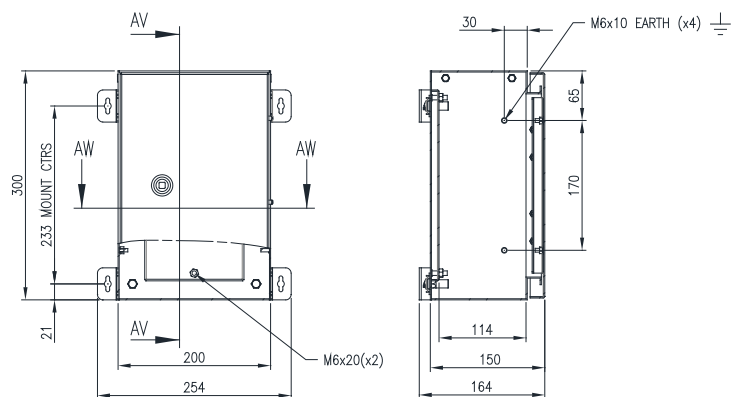

FRONT VIEW

SECTION AV-AV

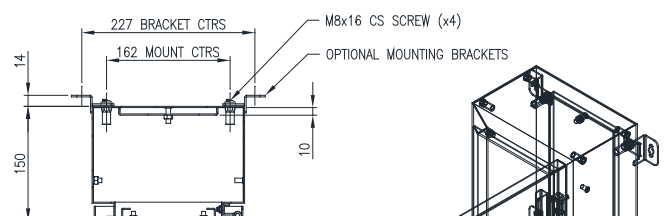

SECTION AW-AW

